

## RF20 Series Reflective Encoders

### Product Description

RF20 series reflective encoder with PCBA and integrated housing design, with code disc, can output three channels of differential signals ranging from 500~4096CPR.

Z signal can be selected from 90°, 180° and 360°, without special instructions, the standard product is 90°.

This product is suitable for small size DC motor, stepping motor and servo motor.



### Product Model

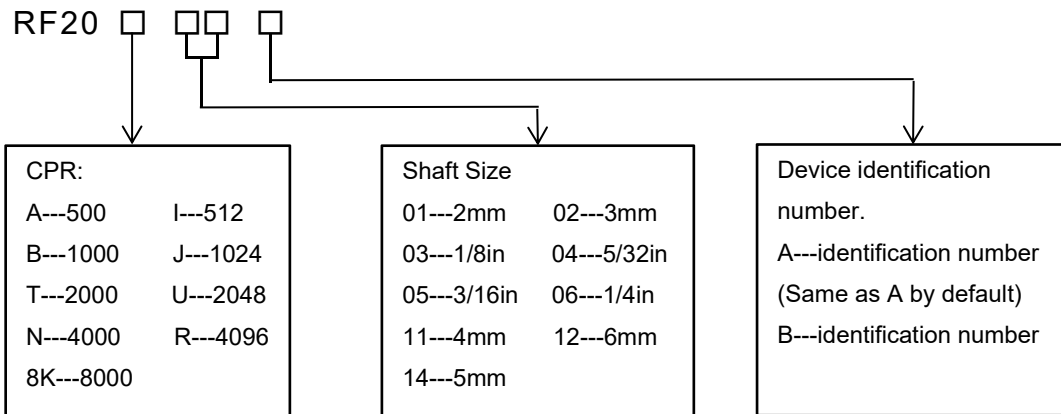

### Technical indicators

Supply voltage	3V-5V
Maximum speed	11000 RPM
Output Method	A、A/、B、B/、Z、Z/
Operating Temperature	-40 °C ~+85 °C

## Waveform Diagram

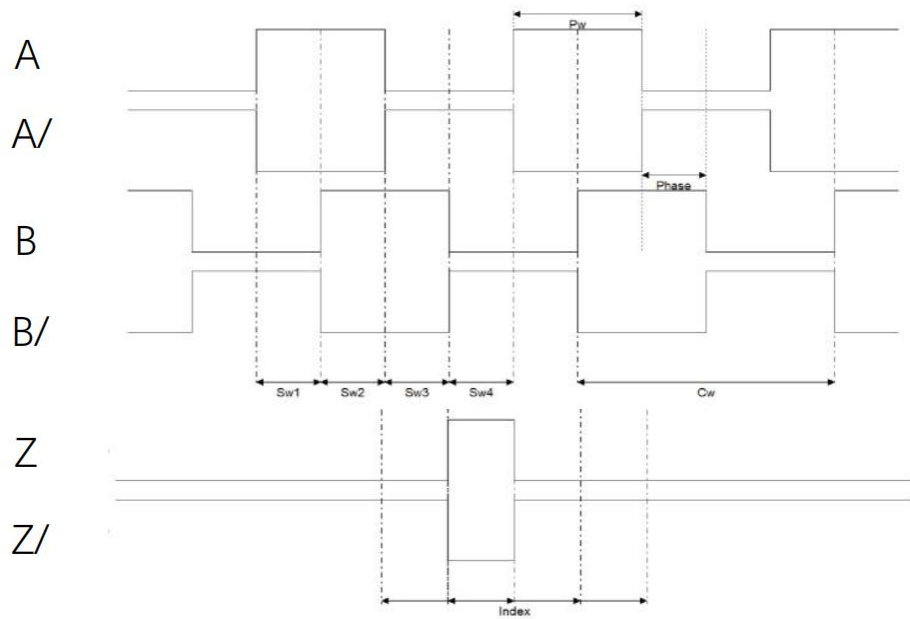

## Pin Definition

Line Number	1	2	3	4	5	6	7	8	9
Identification number A defines	Vcc	Gnd	A	A/	Z	Z/	N.C.	B	B/
Identification number B defines	Vcc	Gnd	A	A/	B	B/	Z	Z/	N.C.

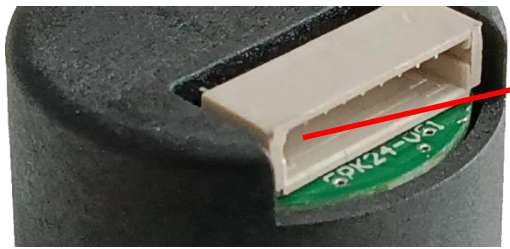

Line number 1

Plug Recommended  
Model: SHR-09V-S

## Mechanical Dimension Drawing

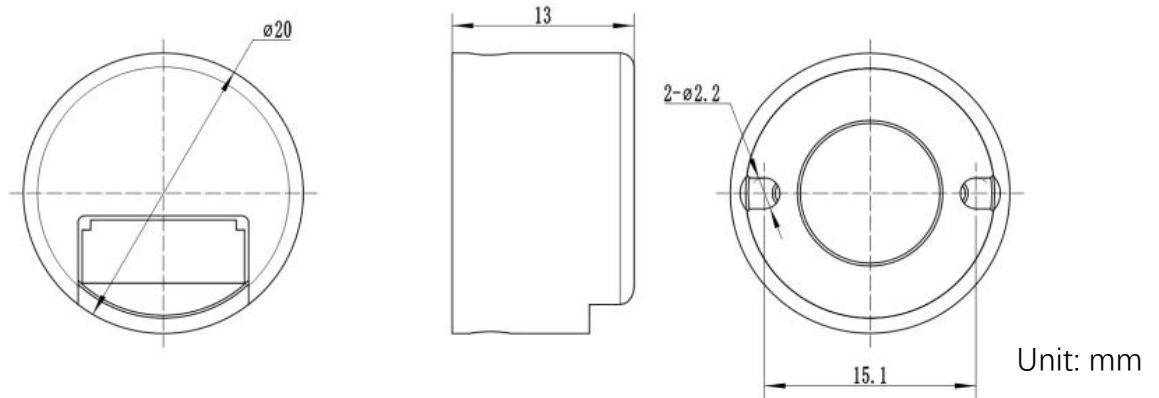

## Dimensions Of Motor End Face and outgoing shaft length

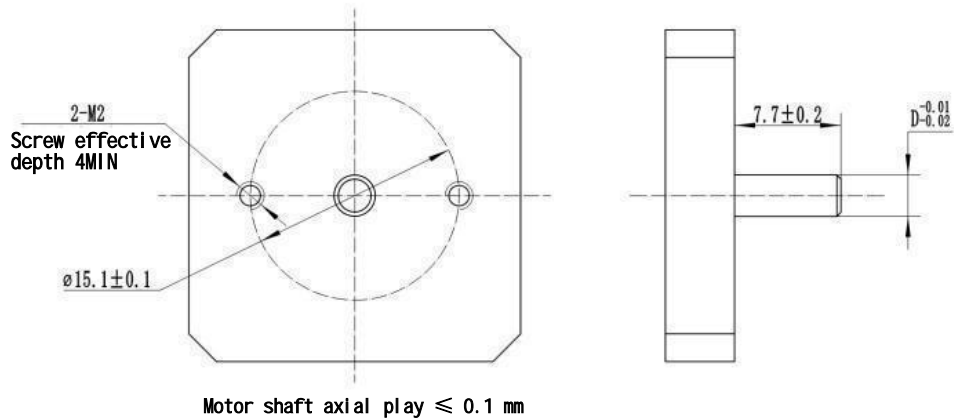

## Model Print

